

Computers: Inside and Out

Lesson 3: Bits & Bytes

Did you know that all of the information that travels through your computer is based on two commands? It's true. The only data that a computer can understand is on and off. But, the millions of combinations of those two commands given in series are what make a computer work.

Binary Code

Remember the power supply that is inside your computer and how it sends electricity to all of the components? That electricity is what creates an on signal. The memory chips inside your computer are divided into thousands of tiny compartments called bits. Each bit has an electronic switch or gate. On means the gate is open and letting electricity go through. The computer reads on or open switches as a number 1. Closed gates are off because the electricity is blocked and cannot get through.

The computer reads off bits as 0. It is by grouping these bits together to form a series of 1/0 commands, that data is formed. Eight bits are grouped together to form a byte. In this group of eight, there are 256 possible combinations of 1/0. The grouping of 1/0 within a byte is called Binary Code.

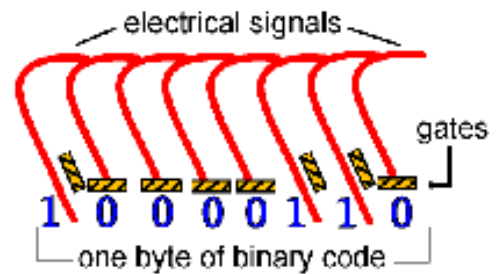

Here's an example of the Binary Code in action:

When you type the letter A on your keyboard, electrical signals are sent from the keyboard to the CPU. The CPU turns the signals into binary code. Then, the computer reads the code and sends it on to the monitor to display the letter A.

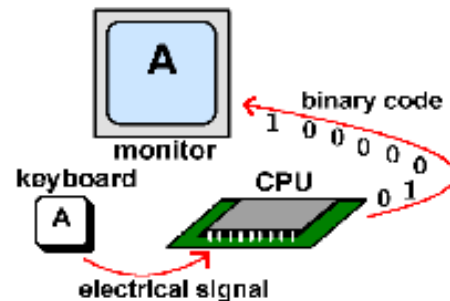

KB, MB & GB

You may have seen these abbreviations many times before. Do you know what they mean?

KB = kilobyte = about 1,000 (one thousand) bytes, (1024 or 2^{10})

MB = megabyte = about 1,000,000 (one million) bytes, (1,048,576 or 2^{20})
GB= gigabyte = about 1,000,000,000 (one billion) bytes (1,073,741,824 or 2^{30})

As you can see, these abbreviations stand for a specific number of bytes. And each byte holds 8 bits capable of forming 256 combinations of 1/0. Wow!

The number that comes before one of these abbreviations represents the computer's memory capacity. For example, if a computer has 64MB of RAM that means that the computer can handle 64,000,000 (64 million) bytes of random access memory (that's 64,000,000 microscopic 8-bit panels). Hard disk space is also measured in bytes. So, a 15GB hard drive has 15,000,000,000 (15 billion) bytes for storing memory.

Look at your keyboard. Each character key is represented by a number that is held in a single byte. Remember how the letter A is sent to the CPU to be translated into binary code? The numerical value of the uppercase letter A is 65. That number 65 is represented in one byte - a combination of 1 and 0 or on and off switches. The computer cannot understand letters, so it translates them into numbers that are represented by patterns of on and off. To get an idea of how much on/off data a computer can store, just imagine pressing one key one billion times! How long would it take? If you pressed the key 5 times per second, it would take you over 6 years of continuously typing to reach 1 billion keystrokes equal to 1GB of memory! And many computers today can store over 20GB of memory on their hard disks! Incredible! So, the next time your computer is taking a long time to load a web page, think of how fast it really is going!

Lesson 3 - Vocabulary

Instructions: Type the words in a Word document, in the order given. Include appropriate school heading. Definitions can be found at the site below, if not, use your lesson material to write a definition.

Definition site NOTE: * means you must write a definition from the chapter.

1. Bit
2. Byte
3. *Gate
4. *Binary Code
5. KB
6. MB
7. GB
8. Main Memory